

LED Vapor Tight - Watts and CCT Tunable



Application: Parking garages, shopping centers, car washes, and many other commercial or industrial applications



FEATURE

- Wet location rated with IP66 ingress protection rating. Suitable for damp location
- Watt and CCT adjustable to fit for different locations
- Long life hours with a durable housing
- 1-10V dimmable: Light can be dimmed to ideal brightness levels to save energy and get the light levels correct for your area.
- With option of build-in motion sensor or emergency backup driver

ACCESSORIES



- Plastic Anchors
- Screw for anchor
- Strain Relief Connectors
- Mounting brackets (2 for 2FT/4FT and 3 for 8FT)

ORDERING GUIDE

Model	V4H-PEF-BD520-SW	
Power	20/30/40W Selectable	
Size	4FT	
Lumens	5200 lm @ 40W	1
Cover	Clear Ribbed	
Input Voltage	120-277 VAC	
Dimming	Triac Dimming (10%-100%)	
Protecting Rating	IP66	
Power Factor	0.9+	
Beam Angle	120°	
CCT	3000K/4000K/5000K Selectable	
CRI	80+	
Surge protection DM/CM	1.25 kV / 1.25 kV	
Working Life	Lumen Maintenance over 70% @50,000+ hours	
Oper. Temperature	- 13°F ~ +113°F / -25°C ~ +45°C	
Housing	Polycarbonate housing (PC) + Stainless Steel Clips	
Option (XX)	XX can be: MS: Microwave Motion Sensor EM: Emergency Backup Driver	

LED Vapor Tight - Watts and CCT Tunable

DIMENSION

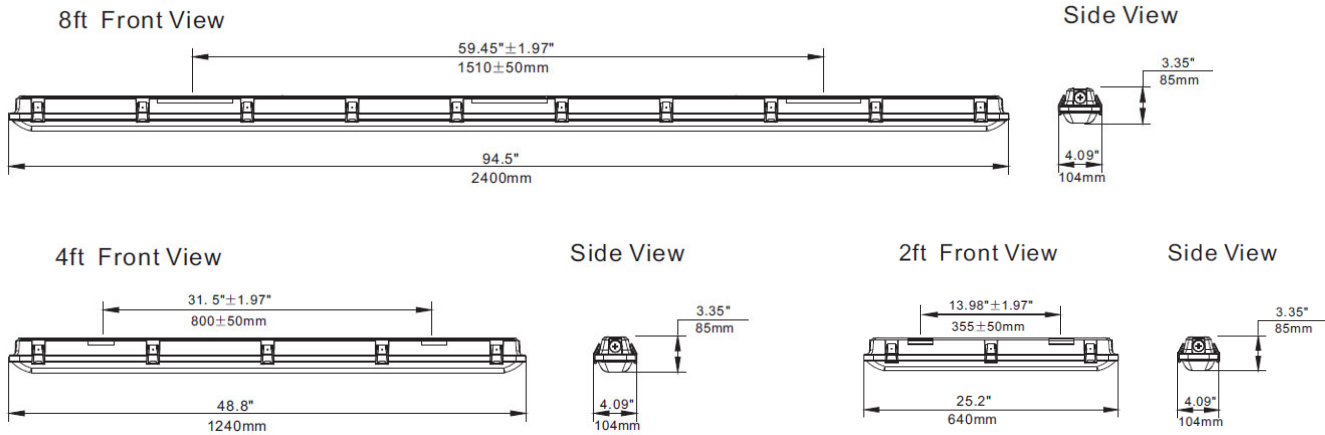

PACKAGE INFO

Model. No.			
Size	2FT	4FT	8FT
QTY/PACK	6PCS/PACK		4PCS/Pack
Package Size	690X245X280mm 27.2"X9.65"X11.02"	1290X245X280mm 50.8"X9.65"X11.02"	2450X245X200mm 96.5"X9.65"X7.87"
Package Weight	9 kg/19.84 lbs	15.1 kg/33.29 lbs	24 kg/52.91 lbs
Package CBM	0.047334	0.088494	0.12005
40GP Capacity	~7350PCS	~3930PCS	~1930PCS
40HQ Capacity	~8610PCS	~4610PCS	~2260PCS
45HQ Capacity	~9880PCS	~5280PCS	~2590PCS

PHOTOMETRIC REPORT

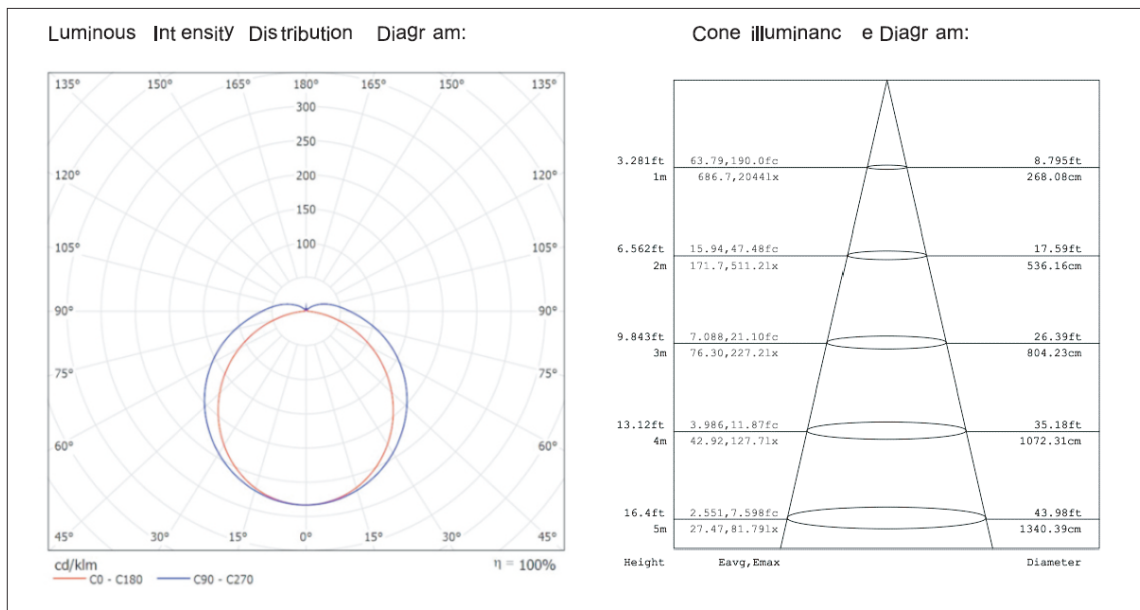

LED Vapor Tight - Watts and CCT Tunable

Watt and CCT Selectable

Surface Mount Installation

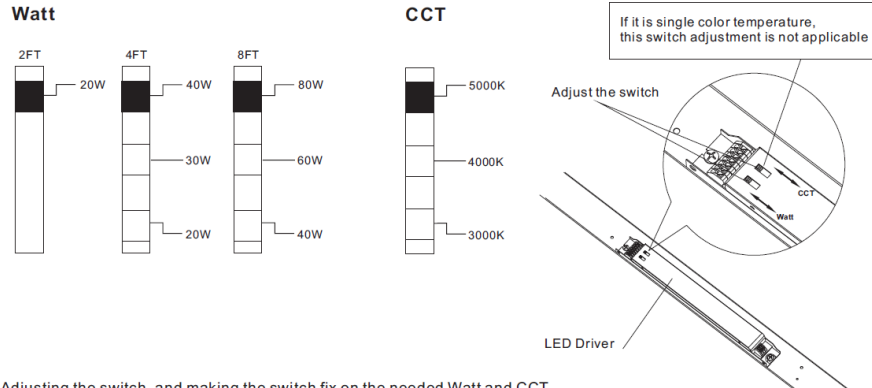

Adjusting the switch, and making the switch fix on the needed Watt and CCT.

Note:

Due to different LED driver models,

The specific functions of the switch are subject to the actual switch label of the LED driver supply

Installation

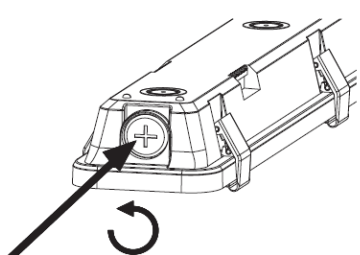
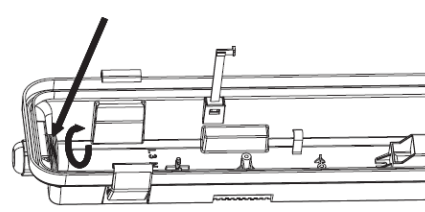
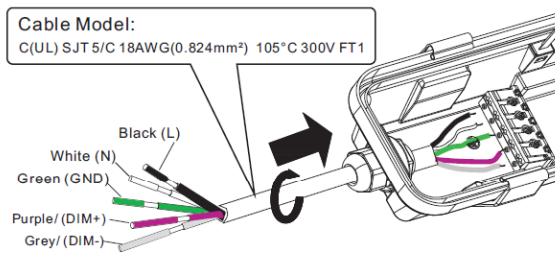
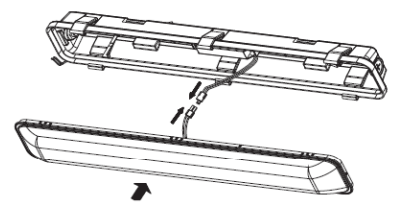
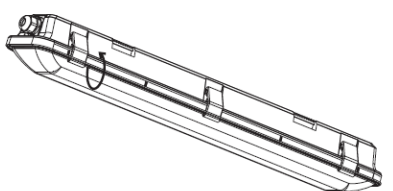
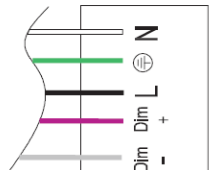
 <p>1 Take down the quick end cap anticlockwise.</p>	 <p>2 Fasten the waterproof connector clockwise.</p>
<p>Cable Model: C(UL) SJT 5/C 18AWG(0.824mm²) 105°C 300V FT1</p>  <p>3 Insert the cable through waterproof connector and wire it into terminal block. Make sure L, N, grounding and dimming wire are wired to correct holes.</p>	 <p>4 Connect the male plug extended from back^k of reflector to the female plug from the driver.</p>
 <p>5 Close the lamp diffuser, which was integrated with reflector, and lamp base, then fasten the clips which were offered in accessories bag.</p>	<p>• Connection mode</p> <p style="text-align: center;">Dimming function</p> 

LED Vapor Tight - Watts and CCT Tunable

Build-In Motion Sensor Information

BUILT-IN MOTION SENSOR INFORMATION

ANT-3A

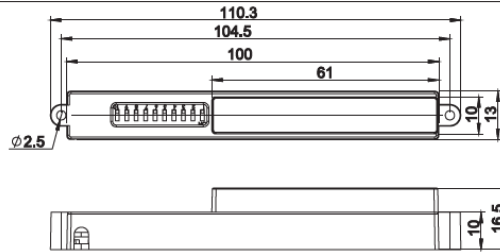
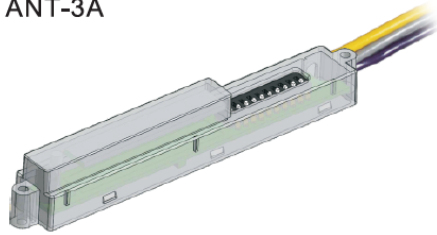

⚠ WARNING

NOTE: Warm up time is 15seconds. After the sensor connects input power first time, the light will keep on 15 seconds, then go to dimming to work normally.
NOTE: Factory Default Setting: 100% sensitivity, Hold on time: 10seconds, Daylight sensor is 30lux, Dimming level:30%, Dimming time: 60minutes.
NOTE: Any setting changed by DIP Switch or remote control, the led light that sensor connect will on/off as confirm.

SPECIFICATIONS

Power supply	12V-24V DC, >50mA
HF System	5.8GHz±75MHz
Dim control output	0-10V, max. 25mA sinking current
Detection radius/angle	Max 17ft.(5.2m)/360°
Mounting height	Max 13ft(4m)
Remote range	50ft. (15m) Indoor, no backlight
Humidity	Max. 95% RH
Temperature	-40°F ~ 158°F (-40°C ~ 70°C)

PARAMETER SETTING BY DIP SWITCH

Consider the picture: 1, 2 set sensitivity; 3, 4 set hold time; 5, 6 set the lux; 7, 8 stand-by light level 9, 10 set stand-by time;

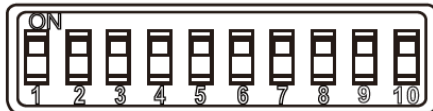

For detailed adjustment methods, please refer to the ANT-3A instruction manual

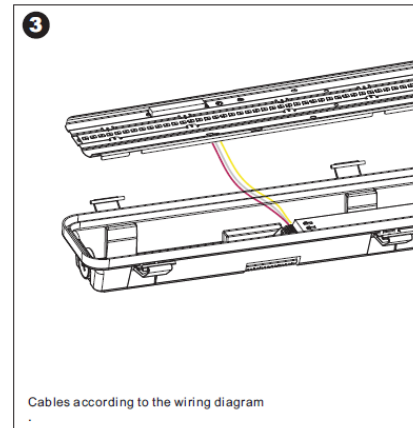
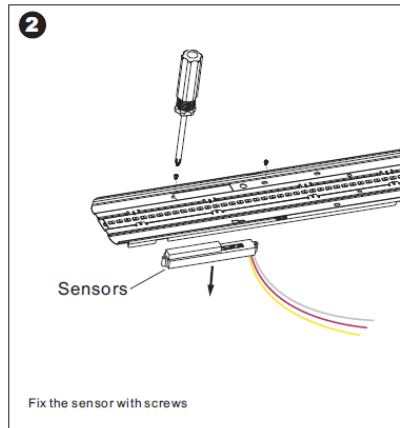
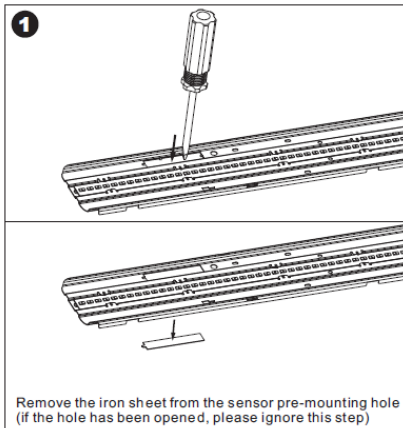
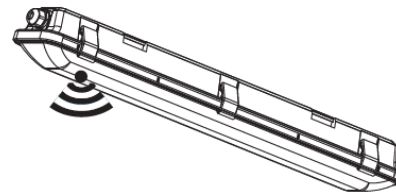

WIRING DIAGRAMS

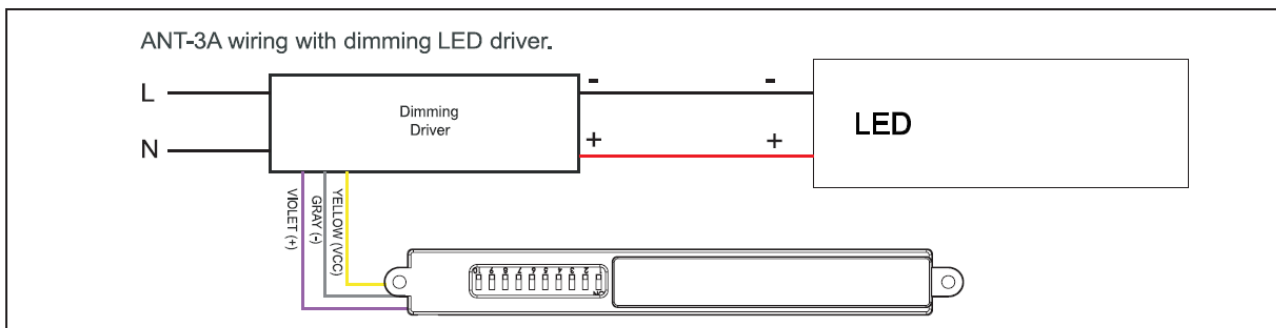

LED Vapor Tight - Watts and CCT Tunable

Build-In Emergency Information

EMERGENCY LED DRIVER INFORMATION

Specifications:



Specifications:

Universal Input Voltage	100-277Vac 50/60Hz
AC Input Current	100mA max.
AC Input Power Rating	7.0W max.
Output Current and Voltage	160-320mA 25-48Vdc
Output Power	8W
Emergency Time	≥1.5H
Full Warranty	5 Years
Test Switch Indicator Light	Illuminated Test Switch, indicator Light
Battery	Li-ion battery-7.4V/2500mAH
Battery Charging Current	250mA
Charging Time	≥24Hours
Temperature Rating (Ambient)	Li-ion 0°C to +40°C (32°F to 104°F)

WIRING DIAGRAM

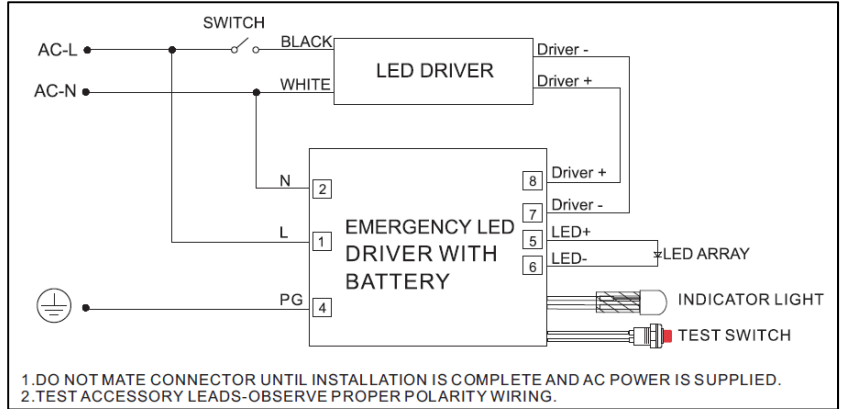

INSTALLATION

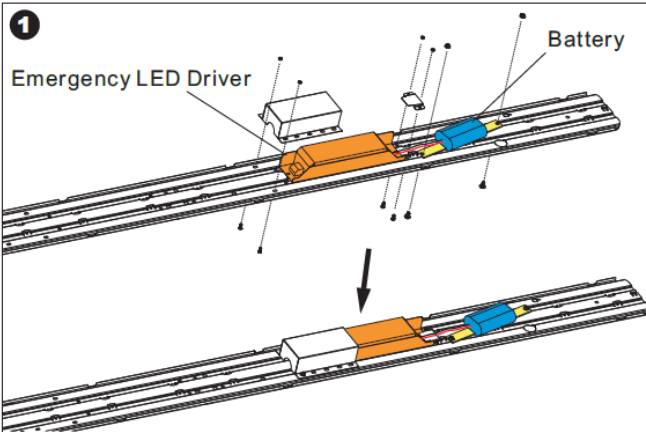

Emergency led driver and Battery installation position

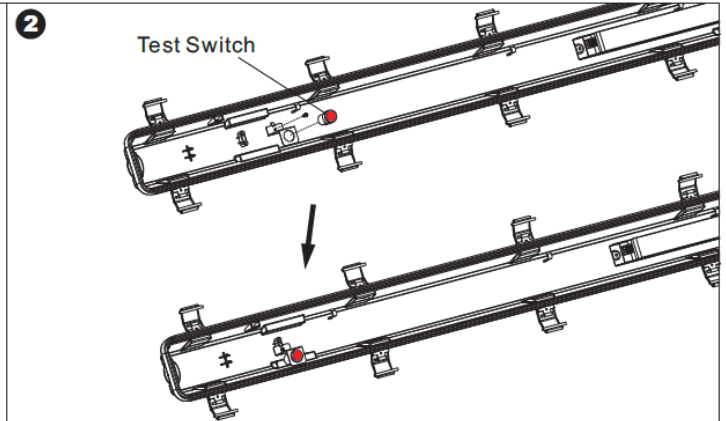

Test Switch installation position

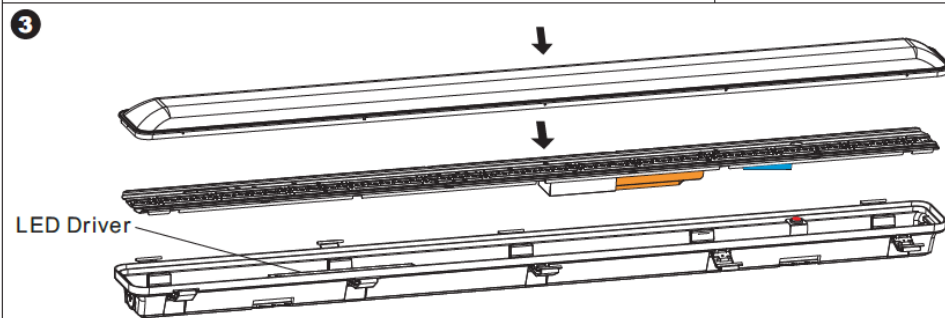

Assemble according to this drawing and wire according to the wiring diagram to complete the installation